

Applications

PE and PP structured wall pipes

Krah profiled pipes

Water is of vital importance: Without water no life would exist and our planet would be a huge desert. Plants, animals and humans are composed of 50–80% water, from polluted water or water scarcity however, they suffer, fall ill or even die. Therefore, our common future is endangered when water is not available in sufficient amount and quality.

Water is a heritage of nature and it belongs to all living beings. The right of access to sufficient and clean water is a universal law and it is therefore anchored in important international treaties. The uneven distribution of rain and water on Earth leads to water scarcity in many regions. Already today 1 billion people (20% of the world population) have no secure access to clean drinking water and 2 billion people do not dispose of access to sanitary installations. Thousands of children die every year due to polluted water. Moreover global climate change will intensify the water crisis.

All these facts force the world population to react in order to rescue our home planet.

To improve this situation and find solutions a lot of governmental bodies, engineering and construction companies as well as pipe manufacturers have focused in this world threatening issue.

However, for years tremendous difficulties were observed when selecting the material of construction for infrastructure systems which should be suitable to provide anticipated permanent solutions.

Over the last decades the inherent weaknesses of concrete, clay, ductile, PVC and steel caused tremendous problems in existing sewer pipe systems, as they tend to be brittle or are too sensitive to aggressive chemicals and soil conditions. Failures had become a common occurrence worldwide in sewer and other large-diameter-pipe applications. In addition they have a unprofitable relation between cost and benefit.

So Krah derived benefit from the fact that the processing of polyolifines is very easy and the plastic materials provide superior properties against adverse effects of the ambient and the chemicals.

In addition to the permanent solution that lasts through generations, Krah piping system is able to provide everlasting and economic solutions in wide-ranging fields of applications as for example drain, stormdrain and sewer systems as well as sea outfall, manholes and reservoirs.

In order to meet the requirements of the infrastructure systems, Krah has developed the most robust and advantageous largebore-pipe systems of which all features are described in detail in this brochure.

Production technology at the highest level

Krah AG is a German machine manufacturer with over 35 years of experience in the design, development and construction of production plants for large diameter pipes. The machine is equipped with all necessary components to produce pipes and fittings with all different kinds of sizes and stiffnesses as well as the profiles mentioned on the following pages. Even the complete range of diameters can be produced on one machine by using the production tools in the required diameters.

Basically Krah pipes are produced in an extrusion process, where a profile is wound around a collapsible steel mandrel. The profile can be solid wall or structured wall.

Beside the extensive pipe range that can be produced, the main features of the machine are a high production output, the simple operation and short change-over times.

Thanks to very close cooperation and a steady information flow with our customers world-wide, we are always up-to-date regarding upcoming demands and changes on the pipe market. This gives us the possibility to develop necessary modifications to our machines in order to respond to the needs of our customers.



Outfall pipe line DN/ID 2000mm



Sewer pipeline DN/ID 2000mm



Sewer line DN/ID 1200mm with bend and manhole jointed by electro fusion



Silos for raw material

Krah profiled pipes

Material

Polyethylene (PE63, PE80 and PE100) and polypropylene are thermoplastics with excellent properties for the application of water and sewer, as well as for the fabrication of containers for liquids and solid materials. The environmental friendly polyethylene and polypropylene are resistant to many chemicals and very suitable for conveying and storing various liquids.

Krah pipes can be produced of the following thermoplastic materials:

- High density polyethylene (PE80 and PE100)
- Polypropylene-random (PP-R)
- Polypropylene-homo (PP-H)
- Polypropylene-none-flammable (PP-S)

These materials feature below mentioned properties. Other materials can be used after prior acceptance of the producer and a third party for quality control. However, the processed material should have the below listed specification.

Typical material specification						
Property		Standard	Unit	PE 80	PE 100	PP-R
Density		DIN 53479 ISO 1183	g/cm ³	0.95	0.96	0.91
melt index MFR 190/5 MFR 190/21.6 MFR 230/5	Code T Code V Code V	ISO 1133	g/10 min	ca. 0.43 ca. 10 -	0.45 6,6 -	0.50 - 1.25-1.5
tensile modulus short-time long-time (50 years)		ISO 178	N/mm ²	1.000 170	1200 170	750 160
yield stress		DIN 53495	N/mm ²			
tensile strength		DIN 53495	N/mm ²	32	38	15
elongation at break		DIN 53495	%	> 600	> 600	> 50
ball indentation hardness		ISO 2039	N/mm ²	42	46	45
coefficient of linear thermal expansion		DIN 53752	1/°C	1.8 x 10-4	1.8 x 10-4	1.6 x 10-4
colour		-	-	black/yellow	black/yellow	grey

Since the latest developments, high stiff polypropylene can be used, if you are interested ask for further information and data sheets.

Pipe Diameter

Krah pipes can be produced stepless at intervals of 100mm with internal diameters (ID) from DN 300mm to DN 4000mm.

The nominal diameters (DN) coincidents with the internal diameter (ID) of the pipe, because in case of any change in the design of the pipe, the wall thickness can be increased or reduced while the internal diameter remains the same. This ensures that the designated hydraulic capacity for the installation is maintained.

DN/ID	DN/OD range
300 mm	310 - 460 mm
400 mm	410 - 560 mm
500 mm	510 - 660 mm
600 mm	610 - 760 mm
800 mm	810 - 960 mm
1000 mm	1010 - 1160 mm
1200 mm	1210 - 1360 mm
1400 mm	1410 - 1560 mm
1600 mm	1610 - 1760 mm
1800 mm	1810 - 1960 mm
2000 mm	2010 - 2160 mm
2200 mm	2210 - 2360 mm
2400 mm	2410 - 2560 mm
3000 mm	3010 - 3160 mm

Krah Pipes OÜ production range

Pipe length

The standard laying length (L) of the Krah pipes is six meters, because in this way they are easy to handle, store and transport.

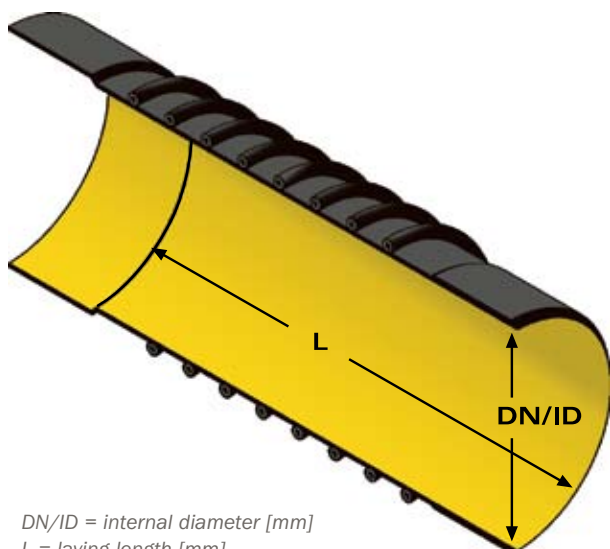

DN/ID = internal diameter [mm]
L = laying length [mm]

In addition it is possible to produce continuously any length between one and six meters. The longer a pipe is the fewer joints are necessary and this is advantageous for the installation of the pipe. Moreover it is possible to deliver the pipes already jointed, whereby the installation time on site can be reduced significantly. Lengths up to 18m consisting of 3 pipe sections are common.



Bending of Krah pipes $R/D = 30$

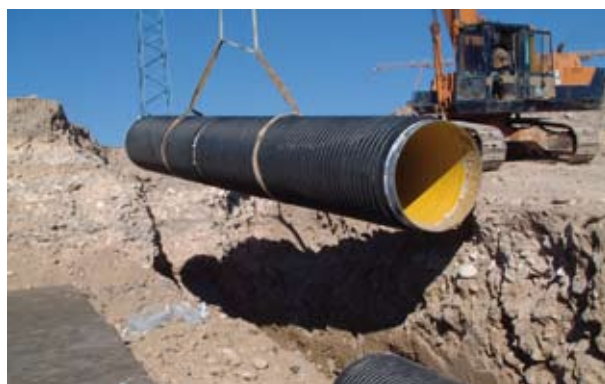

Installation of two pre-jointed pipes DN 1600mm



Storage of different kind of pipes



Special bend

Krah profiled pipes

Wall thicknesses

Both profiled and solid wall pipes with wall thicknesses up to 300mm can be produced.

Minimum wall thickness according to EN 13476 table 5

Normal pipe size DN/ID [mm]	s1, by PE [mm]	s1, by PP [mm]
300	2.0	2.0
400	2.5	2.5
500	2.5	3.0
600	3.3	3.5
800	4.5	4.5
1000	5.0	5.0
> 1200	5.0	5.0

The quality of the pipe is highly depending on the quality of the waterway wall, therefore all Krah pipes are usually produced with a minimum waterway wall of 4mm.

Profiled pipe wall

The great advantage of this development is that a profiled pipe has a very low weight, but at the same time can be used for high load applications. A lot less material is needed to produce a pipe with the same statical properties than a solid wall pipe, which means significant savings in material costs.

The supportable static load is determined for every profile geometry by the factors elastic modulus [N/mm²] of the respective material and the moment

of inertia of the profile geometry [mm⁴/mm] referring to the pipe diameter. The result is called ring stiffness. By using a profile design pipe, the weight can be reduced up to 65% compared to a solid wall pipe with the same ring stiffness. Krah pipes offer the best security and durability. The wall thicknesses of our pipes can be adapted in small steps to the respective load.

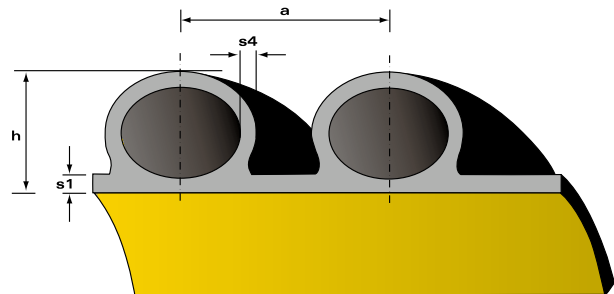

- a = profile distance [mm]
- s1 = waterway thickness [mm]
- s4 = coating thickness [mm]
- h = profile height [mm]

Internal pressure

The Krah pipe system can withstand low working pressure up to 3 bar, depending on the thickness of the waterway wall (s1). Equivalent to DIN 8074 the hoop stress formula can be used to calculate the s1 as the minimum wall thickness.

Co-extrusion

If requested all pipes can be delivered either with a bright, inspection friendly or an electro-conductive inner surface made by the co-extrusion process.

The co-extrusion ensures an inspection friendly, bright inner surface and at the same time a long term UV-resistant outer surface (for example for the storage of pipes outside for a long time).

Norms and standards

The Krahe piping system is designed to meet the requirements of present applicable international norms and standards. Krahe AG is member of the major standardization committees to guarantee that the pipes are corresponding to the standards, but also that the standards are corresponding to the pipes.

The Krahe pipe corresponds to the following international standards:

Subject	Standard
Pipe	DIN 16961, pr EN 1347-1 or on request ASTM F 894 NBR 7373 JIS K 6780
Statical dimensions	ATV A 127 ISO 9969
Hydraulic dimensioning	ATV A110
Pipe installations	EN 1610
Welding	DVS 2207
Internal standard	KWS



Krahe pipes installed in a very narrow trench



Transportation of Krahe pipes



Shaft DIN/ID 2200mm



Different co-extrusions – yellow, blue and electro conductive

Pipe properties

Weldability

Due to the thermoplastic material the pipes can be welded together which signifies, that the whole pipeline builds a homogenous system and is absolutely safe against infiltrations and exfiltrations.

Good chemical resistance

For buried pipelines the biogenous sulphuric acid corrosion plays a key role regarding the longevity of the system. The biogenous sulphuric acid corrosion only takes place above the water level and therefore only occurs in partly filled pipes. Thanks to the used material Krah pipeline systems guarantee optimum security and resistance.

Impact resistance

The high impact resistance, even at low temperatures, ensures a robust pipe, resistant against impacts during transport, installation on the site and during the whole service life conditions.

Recycling

Polyethylene and polypropylene can be recycled to 100%. These materials have the property to be reworkable without the structure of the material having to be modified dramatically. For this reason all waste material of polyethylene and polypropylene pipes can be led back into the production cycle.

Resistant to microorganisms, rodents and termites

The smooth round surface of plastic pipes does not give the teeth of rodents sufficient hold to cause damage. Moreover even in termite-affected countries no damage to polyethylene pipelines by termites has ever been occurred. Polyethylene and polypropylene are not a nutrient medium for bacteria, fungi and spores, so that the material is resistant to all forms of microbial attack as well as to both sulphurous acid and sulfates.

Hydraulics

Inner diameter and hydraulic properties of Krah pipes will remain constant regardless of the wall thickness or the profiles due to the smooth anti adhesive inner pipe surface. The nominal diameter (e.g. DN/ID 500) corresponds to the respective inner diameter according to DIN 16961.

Compared to other pipe materials like concrete, smaller diameters can be used, which means that costs for material and installation can be reduced considerably.



Wall roughness

Abrasion resistance

Polyethylene and polypropylene pipes are among the most abrasion proof pipes. This has been tested in the so-called Darmstadt procedure and the results are shown in the below diagram and confirm the quality of polyethylene pipes. Tests have been performed at the "Süddeutsche Kunststoffzentrum" for its approval.

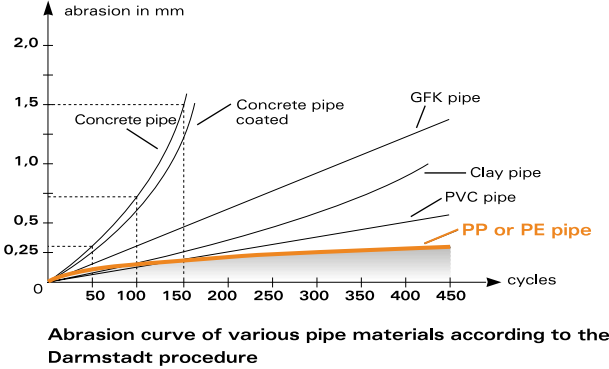

Abrasion curve of various pipe materials according to the Darmstadt procedure

UV-resistance

Black polyethylene pipes are permanently resistant to atmospheric corrosion and UV radiation. Thus the pipes can be used and stored outside without the pipe material being damaged. No aging effect will occur.



Wall of a SQ pipe



Storage of pipes



The easy handling of Krah pipes



Manual unloading of a pipe DN/ID 600mm

Pipe properties

Specific light weight

The Krah pipes have a very low weight and therefore are easy to handle during installation, which makes the usage of a crane on site in most of the cases unnecessary.

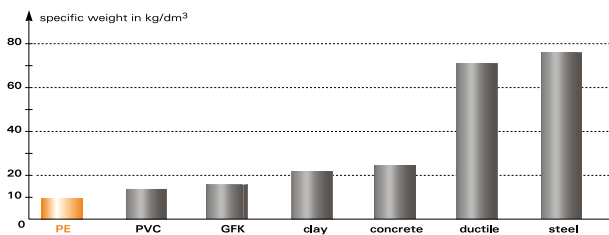

Material characteristic values



By using profiled pipes we can save weight up to 65% compared to equivalent solid wall pipes with the same statical capacity.

Deformation resistance

Elastic pipes can react to changes in their environment. Due to the deformation performance, the load is distributed to its surrounding and the force acting on the pipe will be diminished. Within a short time there is a balance in the area around the pipeline

and the deformation comes to a standstill. Plastic pipes react very flexible to static loads, while the loads do not concentrate themselves on the pipe, but are diverted to the surrounding soil. Flexible pipes still function, when other rigid pipe systems have already broken. Even in the case of a deformation the system is still absolute resistant against infiltration and exfiltration.

Since the pipes are profiled on the outside, these profiles can fix the pipes in the soil. There will be no or very few axial extensions in the pipeline. Krah pipes are nearly unaffected by temperature variations.

Flexibility

Pipes made of Polyethylene and Polypropylene have considerable advantages to other pipe materials like concrete, steel, ductile etc. Due to their material the Krah pipes possess over a high elongation at break. This signifies, that the pipe can support even loads or deformations, that were not included in the actual calculation and design of the pipe, like for example earthquakes. The Krah pipes deform conform with the movement of the earth without any breaks or cracks, so that the activity of the pipeline is not drastically affected. As soon as the overload and earth movement ends, the pipe will go back to its initial condition and position.

Another advantage is the high flexibility. Even in areas which are highly affected by earthquakes, our pipes are hardly damaged in comparison to pipes made of other materials. Despite the flexibility of the Krah pipes they have a great capacity to carry loads, so that they are also suitable for road construction.

Deflection is safety

Deflection of flexible pipes is controlled by the settlement of the soil. After settlement, traffic and other loads do not affect pipe deflection. When pipes are relatively more rigid than the soil, the traffic and other loads have to be resisted by the pipe.

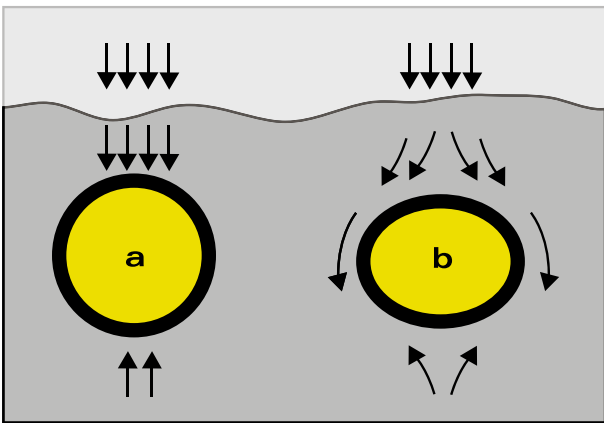

Deflection of flexible pipes compared to flexural resistant pipes

Many years of practical experience have shown that flexible pipes (b) can resist traffic and other loads more effectively than flexural resistant pipes (a) made of concrete or other rigid material.

As shown in the drawing, the flexible pipes elude a selective strain by deflection. By this means the surrounding soil absorbs this strain.



Quick manhole installation



Installation of a sewage pipe with a complete manhole



Installation of a pipe DN/ID 2000mm



Installation of a TWIN-pipe DN/ID 2000mm with fittings

Profiles

One of the great advantages of Krah pipes is that it is easily adaptable to all different kinds of project requirements.

According to different norms and standards, the pipes shall be designed according to nominal ring stiffness classes (SN) like SN2 (only for pipes DN > 500), SN4, SN8 or SN16 (according to ISO9969), or other standard stiffness classes (DIN16961, ASTM F894, NBR 7373 etc) not depending on the testing method (constant speed or constant load).

In addition, according to EN13476-3 9.1, the manufacturer is also allowed to produce pipes DN/ID > 500mm in between the SN classes, in case he is able to prove and underline this decision with the help of a static calculation.

The real pipe quality consists of the right waterway wall thickness, a good raw material and a secure jointing technology; but not the stiffness.

Profile type: PR



The main properties of the profile series PR is the smooth inside and the profiled outside. The low weight and the high stiffness are significant.

The fields of application for this kind of profiles are pipeline systems like for example sewer, drain, storm drain and ventilation.

Profile no.	I_x [mm ⁴ /mm]	e [mm]	se [mm]
PR 21-000.39	395	6.85	16.80
PR 34-001.23	1229	11.01	24.50
PR 42-001.88	1884	13.14	28.30
PR 42-002.60	2604	14.69	31.50
PR 54-004.39	4386	18.20	37.50
PR 54-004.71	4706	17.62	38.40
PR 54-005.26	5260	20.32	29.80
PR 54-005.66	5561	19.70	40.80
PR 54-006.57	6569	21.54	42.90
PR 54-007.02	7032	21.11	43.80
PR 54-007.98	7983	22.72	45.80
PR 54-008.49	8492	22.41	46.70
PR 54-010.07	10074	23.68	49.40
PR 54-011.77	11774	24.88	52.10
PR 54-012.92	12917	26.14	53.70
PR 54-014.28	14277	26.05	55.50
PR 54-016.32	16321	26.20	58.10
PR 54-019.34	19844	29.97	62.00

List of typical profiles, type PR

I_x = moment of inertia, e = distance of inertia,
se = equivalent solid wall thickness

Profile type: SQ



This profile pipe has a smooth inside and outside including internal profiles with one or more layers. This profile has a very high long-term stiffness therefore it is very suitable for extremely high loads and big diameters.

Profile no.	I_x [mm ⁴ /mm]	e, se
SQ1	9.400 - 27.000	information on request
SQ2	46.000 - 133.000	information on request
SQ3	164.000 - 300.000	information on request

List of typical profiles, type SQ

I_x = moment of inertia, e = distance of inertia,
se = equivalent solid wall thickness

Profile type: SP

Should a standard profile not be sufficient due to the effects of all different kinds of loads, the Krah pipe system makes it possible to combine different kinds of profiles in order to achieve the required effects. For example a PR profile can be added to a SQ profile or a solid wall pipe without any problems.

With this technique, the following two effects are achieved: Both profiles can be statically added whereby a stronger pipe is produced and a profile will be added to the otherwise smooth surface, which has advantages regarding the anchoring of the pipes in the soil preventing the axial deformation.

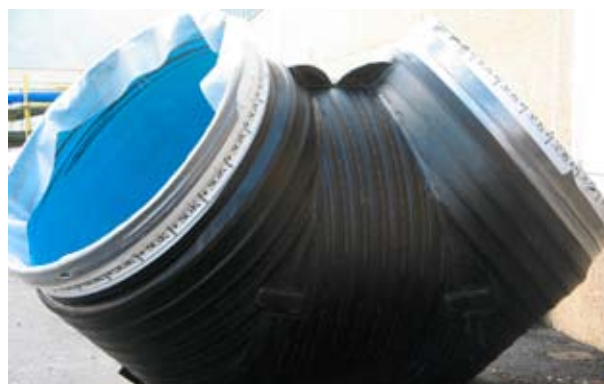

Bend with integrated electro fusion joint



Bend DN/ID 2400mm



Special waste stream cleaning application



Different kinds of fittings

Solid wall

Solid wall pipes

This pipe type has a smooth inner surface and a slightly uneven outer surface. The pipes are produced homogeneously. Moreover this solid wall pipes are tempered, which means that there are no frozen stresses.

Profile type: VW

The type VW is a homogeneous solid pipe with smooth inside and outside surface. These pipes can be used for internal working pressure. The minimum wall thickness measures 5mm, the maximum thickness is 80mm.

s \ DN/ID	5	6	7	8	9	10	11	12	13	14	15	18	20	25	30	35	40
	[kg/m]																
300	4.6	5.5	6.5	7.4	8.4	9.3	10.3	11.3	12.3	13.3	14.2	17.3	19.3	24.5	29.9	35.4	41.0
400	6.1	7.3	8.6	9.8	11.1	12.4	13.6	14.9	16.2	17.5	18.8	22.7	25.3	32.0	38.9	45.9	53.1
500	7.6	9.2	10.7	12.3	13.8	15.4	17.0	18.5	20.1	21.7	23.3	28.1	31.4	39.6	48.0	56.5	65.1
600	9.1	11.0	12.8	14.7	16.5	18.4	20.3	22.1	24.0	25.9	27.8	33.5	37.4	47.1	57.0	67.0	77.2
700	10.6	12.8	14.9	17.1	19.2	21.4	23.6	25.8	28.0	30.1	32.3	39.0	43.4	54.7	66.0	77.6	89.3
800	12.1	14.6	17.0	19.5	22.0	24.4	26.9	29.4	31.9	34.4	36.9	44.4	49.5	62.2	75.1	88.1	101.3
900	13.6	16.4	19.1	21.9	24.7	27.4	30.2	33.0	35.8	38.6	41.4	49.8	55.5	69.7	84.1	98.7	113.4
1000	15.2	18.2	21.3	24.3	27.4	30.5	33.5	36.6	39.7	42.8	45.9	55.3	61.5	77.3	93.2	109.2	125.5
1100	16.7	20.0	23.4	26.7	30.1	33.5	36.9	40.2	43.6	47.0	50.4	60.7	67.6	84.8	102.2	119.8	137.5
1200	18.2	21.8	25.5	29.1	32.8	36.5	40.2	43.9	47.5	51.3	55.0	66.1	73.6	92.4	111.3	130.4	149.6
1300	19.7	23.6	27.6	31.6	35.5	39.5	43.5	47.5	51.5	55.5	59.5	71.5	79.6	99.9	120.3	140.9	161.6
1400	21.2	25.4	29.7	34.0	38.2	42.5	46.8	51.1	55.4	59.7	64.0	77.0	85.6	107.4	129.4	151.5	173.7
1500	22.7	27.3	31.8	36.4	41.0	45.5	50.1	54.7	59.3	63.9	68.5	82.4	91.7	115.0	138.4	162.0	185.8
1600	24.2	29.1	33.9	38.8	43.7	48.6	53.4	58.3	63.2	68.1	73.1	87.8	97.7	122.5	147.5	172.6	197.8
1700	25.7	30.9	36.0	41.2	46.4	51.6	56.8	62.0	67.1	72.4	77.6	93.3	103.7	130.1	156.5	183.1	209.9
1800	27.2	32.7	38.1	43.6	49.1	54.6	60.1	65.6	71.1	76.6	82.1	98.7	109.8	137.6	165.6	193.7	222.0
1900	28.7	34.5	40.3	46.0	51.8	57.6	63.4	69.2	75.0	80.8	86.6	104.1	115.8	145.1	174.6	204.2	234.0
2000	30.2	36.3	42.4	48.4	54.5	60.6	66.7	72.8	78.9	85.0	91.2	109.5	121.8	152.7	183.7	214.8	246
2100	31.7	38.1	44.5	50.9	57.2	63.6	70.0	76.4	82.8	89.3	95.7	115.0	127.9	160.2	192.7	225.4	258
2200	33.2	39.9	46.6	53.3	60.0	66.7	73.3	80.1	86.8	93.5	100.2	120.4	133.9	167.8	201.8	235.9	270.1
2300	34.8	41.7	48.7	55.7	62.7	69.7	76.7	83.7	90.7	97.7	104.7	125.8	139.9	175.3	210.8	246.5	282.3
2400	36.3	43.5	50.8	58.1	65.4	72.7	80.0	87.3	94.6	101.9	109.2	131.3	146.0	182.8	219.9	257.0	294.3
2500	37.8	45.3	52.9	60.5	68.1	75.7	83.3	90.9	98.5	106.1	113.8	136.7	152.0	190.4	228.9	267.6	306.4
2600	39.3	47.2	55.0	62.9	70.8	78.7	86.6	94.5	102.4	110.4	118.3	142.1	158.0	197.9	237.9	278.1	318.5
2700	40.8	49.0	57.1	65.3	73.5	81.7	89.9	98.1	106.4	114.6	122.8	147.5	164.1	202.5	247.0	288.7	330.5
2800	42.3	50.8	59.3	67.7	76.2	84.7	93.3	101.8	110.3	118.8	127.3	153.0	170.1	213.0	256.0	299.2	342.6
2900	43.8	52.6	61.4	70.2	79.0	87.8	96.6	105.4	114.2	123.0	131.9	158.4	176.1	220.5	265.1	309.8	354.7
3000	45.3	54.4	63.5	72.6	81.7	90.8	99.9	109.0	118.1	127.3	136.4	163.8	182.2	228.1	274.1	320.4	366.7

Weight of pipes, type VW

s = solid wall thickness in [mm]. Other dimensions and materials on request. Weights without socket and spigot.

Profile type: ST

Pipes with the profile type ST are specially made for vertical tanks, where different wall thicknesses in one pipe are required to save material.

The calculation method is according to DVS 2205.

stepped pipes	minimum	maximum
nominal width (Di)	300 [mm]	4000 [mm]
number of steps (n)	two	six
length of step (L)	200 [mm]	pipe length
wall thickness of step (s)	5 [mm]	300 [mm] for PE 150 [mm] for PP
step distance	5 [mm]	

Technical data of stepped pipes

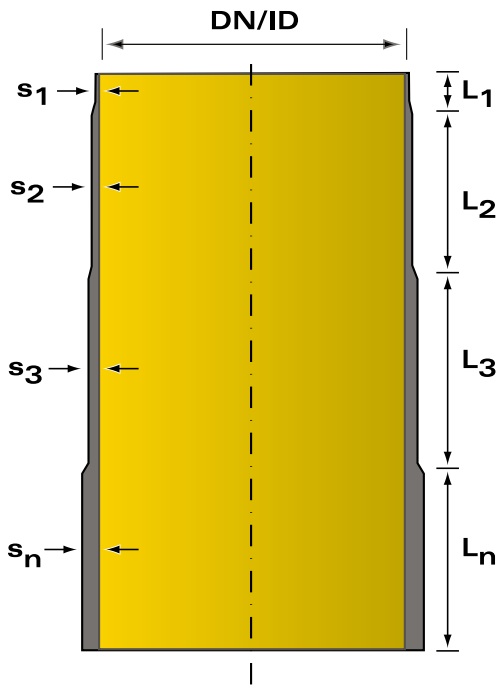

Sketch of a stepped vertical storage tank
 s_1 = wall thickness of the step i
 L_1 = length of the step i



Solid wall polyethylen pipe, $s = 180\text{mm}$



Vertical storage tanks of polyethylene



Vertical "stepped" storage tank for industrial applications



Different types of pipes

Fittings

The Krahe pipe can be provided in the complete range of diameters and stiffness classes but also fittings, manholes and other components are deliverable to accomplish the mission of a homogenous and reliable pipe system.

All fittings are fabricated from pipes of the type VW or SQ. Generally the fittings are designed corresponding to the required stiffnesses and in consideration of the welding factors. Every fitting can have any kind of pipe end and can be assembled with the existing pipe system with any jointing technique.

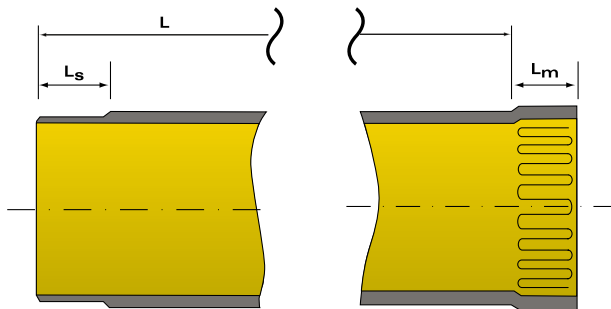

All pipe end dimensions fulfill the requirements of the standard EN 14376, like the minimum lengths and stiffnesses. The standard spigot length (L_s) is 140mm and the standard socket length (L_m) is 140mm.

All fittings are fabricated out of pipes (mainly solid wall pipes) with an equivalent stiffness.



Branches can be manufactured and delivered in every type and form. The angle can be adapted individually from 15° to 90° as well as the ends and the respective segment lengths.

Bends



Bends can be manufactured and segmented in different angles and the related radius of the bend to pipe diameter can be selected independently.

α	Number of segments
15°	2
30°	2
45°	3
60°	3
75°	4
90°	4

Number of segments

In the table the standard bend angles are mentioned, according to DIN 16961 - other diameters on request. Basically every angle can be produced.

Reductions



Reductions can be made both centric and eccentric so that the reductions will always meet the requirements. For standard reductions the maximum difference in diameter is 200mm, other differences on request.

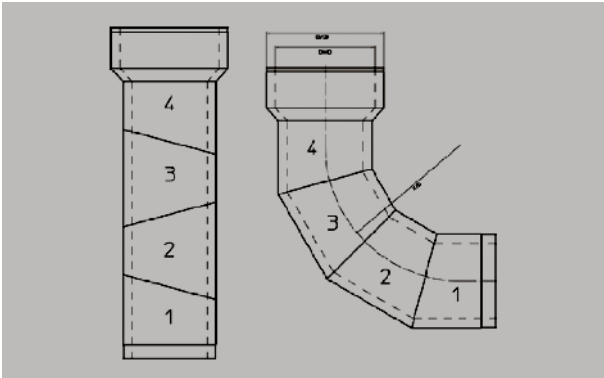

Devision and new arrangement of the pipe segments to create a 90° angle.

House connections

House connections can be installed at any time using our transition sleeves. The house connection can be built onto the profile pipe at any place and in any weather. All usual dimensions for house connection lines are available. The assembly can be carried out by experts on site.

The standard diameters are DN/OD160mm and DN/OD 200mm, but other dimensions are possible.

Following any other kind of pipe system as, for example, corrugated, clay and PVC pipes can be jointed.

Puddle flanges

In order to lead Krah pipes through walls, e.g. in sewage plants or concrete shafts, we recommend our puddle flanges which can be flush mounted in concrete. The tightness is secured by an anchor and a ring made of EPDM.

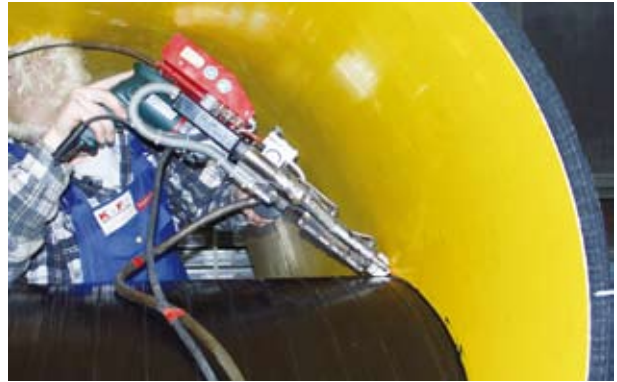

Fabricating of a fitting



Manhole with an integrated bend and electro fusion joint



Bend DN/ID 2000mm



Reduction DN/ID 2400 → DN/ID 1600mm

Manholes

To have the possibility to control and maintain pipe systems regularly, manholes are integrated in the system. These are mainly installed at the positions of bends, reduction or branches. The manholes are made of the same material as the pipes and are also connected to the system with similar jointing techniques. The special advantage is that a homogenous system of the same material is produced. With preference, profile types like SQ and VW are used for the production of the manholes, as the soil can densify better at the smooth outside of the pipe and can settle without problems.

Standard manhole

This kind of manhole is situated centrally above the pipe. Because of static and safety reasons this type is only recommended if the diameter of the pipe is smaller or equal to the diameter of the manhole. Normally the diameters DN/ID 800mm or DN/ID 1000mm are used for this kind of manhole.

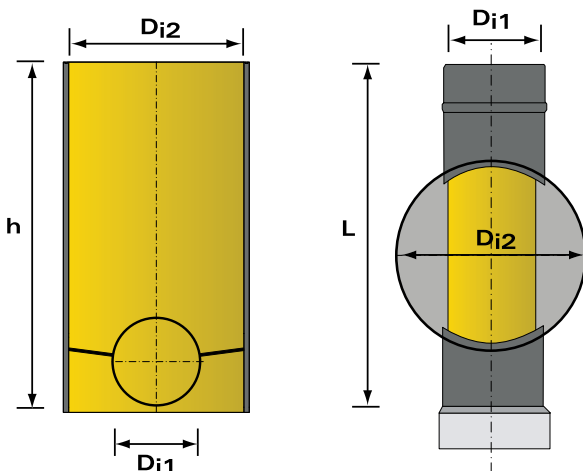

Usually the lower part of the manhole is completely fabricated out of polyethylene or polypropylene according to the static requirements. The upper part is a concrete or reinforced concrete ring according to

DIN 4034. Even very complex constructions according to the engineers requirements are possible. The main advantage is the sustainable, flexible, light weight, inspection friendly, selfcleaning and durable construction.

Tangential manhole

This manhole is situated tangentially to the pipe, that means it is displaced from the middle.

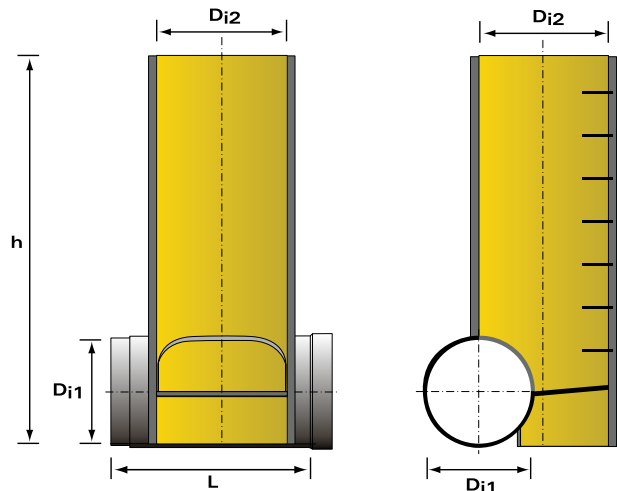

That is the reason why by using this kind of manholes with the standard diameter of DN/ID 1000 it can be also used by pipes with bigger diameters.

Like the standard manhole, the lower part of the manhole is completely fabricated out of polyethylene or polypropylene according to the static requirements. The upper part is a concrete or reinforced concrete ring according to DIN 4034. Even very complex constructions according to the engineers requirements are possible. The main advantage of the tangential manhole is the sustainable, flexible, light weight, inspection friendly, self-cleaning, durable and a very cost effective construction.

Special manhole

If required a manhole made of concrete can be produced with an inlet and outlet designed to connect to the Krah pipe system.

For the cover of the manholes there exist all different kinds of possibilities. Especially the application case and the loads are a major criteria for the correct choice of the cover.

Regularly the manholes are installed in such a way that the top edge is justified to the earth's surface or the street. In this case the cover has to be designed in a way that the direct load conditions, e.g. crossing vehicles, can be carried and forwarded. The most frequently used system is the concrete plate above the manhole which lies on a ring anchor.

The advantage is that the rising loads are not forwarded to the manhole but through the ring anchor to the surrounding earth.

These covers are especially suitable for the installation in roads, as the cover is integrated into the asphalt and flexibly connected with the manhole (telescopic). Thus the cover moves with the asphalt in case that the road settles and the manhole is always even.



Standard manhole DN/ID 1000mm



Special end-manhole with different connections



Inside of a standard manhole with a berm and stairs



Krah pipe with a manhole - produced with bricks

Jointing technology

All Krah pipes are produced automatically with a socket and spigot, which are adaptable to the following kinds of jointing techniques:

Electro fusion joint



This is the most preferred joint system, as the whole pipe system becomes a homogenous unit.

A welding wire which is included in the socket or spigot is heated with the help of a special welding device whereby the two pipe ends (the socket and the spigot) are jointed together. The electro fusion jointing technique is a very favourable, simple and secure method to install pipes in even very narrow trenches in a short time.

For further information please refer to our brochure "Technology - integrated electro fusion joint".

V seam extrusion welding

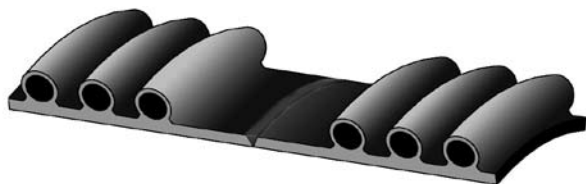

The pipes and fittings are jointed with the help of an extrusion welding extruder. The outside of the ends are chamfered. Thus a welding seam is produced which looks like "V". Normally no socket-spigot connection is used.

The welding has to be done according to DVS 2207 part 4.

Extrusion welding

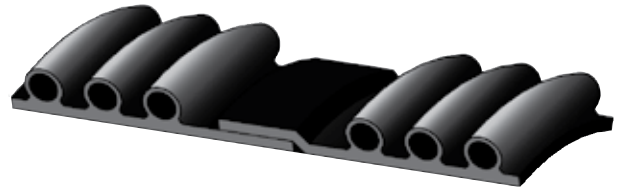

The pipes and/or fittings which shall be connected are jointed by a socket and spigot joint. Thus the two pipe ends are connected with the help of an extrusion welding device. The jointing method can be carried out inside or/and outside of the pipe. This jointing is most suitable for low-pressure gravity pipes and manholes.

The welding has to be done according to DVS 2207 part 4.

Heat element butt welding

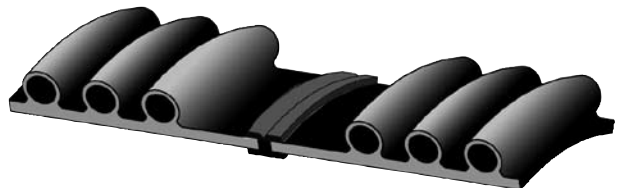

The pipes and fittings are jointed with the help of a heating element butt welding machine. The ends of the pipes and fittings are butt-welded. This kind of jointing method is only recommended for pipes and fittings with a maximum wall thickness of 150mm and with diameters from DN/ID 300mm to DN/ID 2500mm.

The welding has to be done according to DVS 2207 part 1.

Flange connection

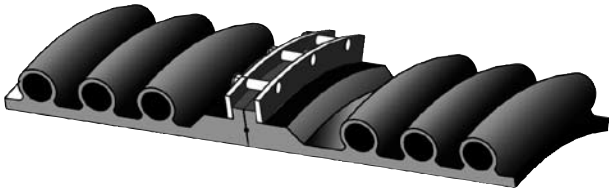

The ends of the pipes and fittings are jointed with the help of a steel flange and a rubber gasket. Depending on the type of pipe the flange adapters are completely manufactured with the pipe, or the flanges are available as separate fitting. This kind of jointing method is mostly used for open sea discharge application and for tank connections. The greatest advantage of this connection is the facility of disjoining.

Gasket connection

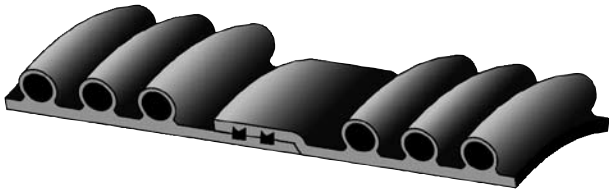

Our system has solid plain socket and spigot, with an integrated EPDM sealing. The minimum wall thicknesses of the spigot is according to EN13476-3 table 7 and in addition the ring stiffness of the socket plus the ring stiffness of the spigot is higher than the ring stiffness of the pipe.



Electro fusion socket



Heat element butt welding connection



Flange connection



Electro fusion connection on site

Applications

Due to the versatility of Krah pipes, with all its different kinds of profiles, they are applicable in all kind of fields of application:

Sewer systems

Sewer systems made of profiled Krah pipes have been used for more than 35 years in all areas of local and industrial drainage. The Krah AG offers a modern sewer pipe program with manholes, fittings, and safe pipe joint systems for the planning of sewer treatment plants.

Outfall pipelines

Water outlets are used for the discharge of liquid and gaseous substances at the base of rivers and the sea. For the construction and operation of such pipelines Krah pipes offer considerable advantages, such as the elasticity of the pipeline and therefore optimum adaptation to the area, low weight, secure and strong jointing technology, seawater resistance and pipe stiffness exactly adapted to the respective requirements because the appropriate profiles are selected for every individual project.

Tanks and containers

Profiled or solid wall pipes made of polyethylene or polypropylene are well suited for the manufacture of horizontal and vertical tanks. For other special constructions like chimneys, compost plants, and wash towers Krah pipes offer all advantages regarding variety, precision, quality, and expandability.

Reservoirs, storm water tanks

Within a sewage system, especially mixed water systems, reservoirs can store rainwater for delayed release to the sewage plant. This will avoid overload. As reservoir systems are usually built-in subsequently, they must be assembled in a very short time. Since the Krah reservoirs are prefabricated, this condition is fulfilled perfectly. Krah pipes offer considerable advantages:

- the compact construction allows short building times
- 100% tight joints between the various elements due to the electro fusion process
- smooth inner surfaces which prevent incrustations
- the pipe's self cleaning ability

Relining

The re-construction of damaged sewer pipes by means of relining, „pipe in pipe method”, becomes more and more important. Krah pipes are very suitable for the relining process. Specific pipe stiffnesses can be calculated for all loads. Also in the area of short pipe relining, Krah pipes offer competent solutions. The welding can be carried out inside the shaft. Pipe lengths are available from 1m to 6m. Krah pipes are able to reestablish the static carrying capacity of the sewer without the need of digging. In order to insert longer stretches, pipe lengths of up to 18m can be pre-fabricated. With pipes DN 800 and larger, it is also possible to insert the pipe one by one into the existing sewer network and weld from the inside of the pipe.

Landfill

Krah is a competent partner for system components for drainage and de-gassing of landfill sites. Many landfill sites have been successfully equipped with profiled drain pipes and manholes. Krah's developments have set new standards for soil and ground water protection. Drain shafts with control systems are available in diameters of up to DN/ID 4000 mm.

Special applications

In addition to the common areas of application Krah pipes are also suitable for special projects like tunnels etc. Krah pipes are also used as ventilating pipes. The advantage over the traditional ventilating pipes which are made of sheet steel, is that they are corrosion-resistant which is especially important for the chemical and biological industry.

Industrial applications

Pipeline systems which have to install for industry applications has superior high expectations. Problem in this field are the chemical constituents and the high temperatures of the transported medium. On this case we can produce special applications.



Sea outfall pipe line DN/ID 1800mm



Main collector of a sewage treatment plant



Relining of a concrete pipe



Industrial ventilation pipes

Installation

With high quality raw materials, which are resistant even against high concentrations of chemicals. Other advantage for this special scope of application is the Krah electro fusion pipe connection. Herewith we can guarantee the high quality not only for the pipe but rather for a complete system.

Pipes made from PP have been proven their quality in industrial praxis.

Transport

The transport of Krah pipes is very easy as they are very good to move due to the low weight. It only has to be ensured, that the pipes cannot move and that they are stored in the right way. In special cases, e.g. if the pipes are shipped in containers, it is recommendable to adapt the total length of the pipe to the shipping conditions in order to use the space most efficiently.

Handling

Forklifts with a rod of 5 meters are very suitable for the handling of the pipe in the production facilities. On site no additional heavy devices are needed. Normally the pipes can be unloaded und transported to the trench by an excavator which anyway is present on site.

Storage

For the storage of the pipes and fittings it is absolutely necessary that they are stored on even ground, free of stones and sharpedged objects, so that point-loads are avoided. Further it is important to make sure that the sockets of the upper layer are not contacting the sockets of the lower layer. This means, the pipes of each layer have to be rotated 180°.

In any case the pipes have to be protected against rolling, especially if the pipes are stored in several layers above each other. A maximum height of 4 meters should not be exceeded.

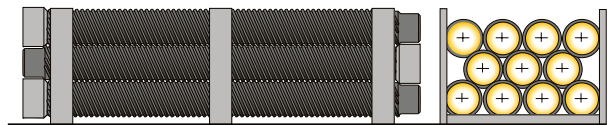

Sample of the storage of Krah-pipes

In addition to the security aspect the pipes should always be stored in such a way that they do not deform. Generally there should be three wood bearing supports to guarantee a good load distribution.

Installation

The installation of Krah pipes is very easy. After the trench has been prepared in the same way as for all other pipes the Krah pipe is laid down und aligned. The individual pipe parts are jointed with the different kinds of jointing techniques.

The backfilling has to be carried out according to the requirements of the statical calculations.

In general, the installation is carried out according to EN 1610.

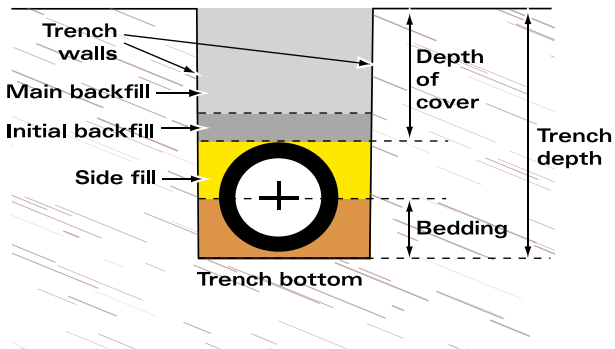

Installation of a Krah pipe acc. to EN 1610



Typical storage of pipes



Installation of a swimming pool storage tank

Leakage test

According to the requirements pipe systems have to be tested for leakage. There exist different kinds of test procedures.

The first alternative is the section test, where the total pipe sections (between two manholes) are tested in all. Air hoses are blown up and they lock the pipes at both ends. Then, water with a certain nominal pressure is pumped into the tightened section. This overpressure is tested after a certain period of time which gives information about the leakage of the section.

The other alternative is the jointing test (only possible with diameters greater than DN/ID 600mm), where only the pipe joints are tested as it is assumed that the pipes themselves are tight. A leakage testing device is used but the testing principle is the same applied in the section test, the only difference is that the test area is the joint.



Installation of a pipe



Installation of rain water tank

Quality control

Total quality management

The quality of the pipes and the pipe products is the criterion for all developments of Krah AG and companies using the Krah technology. As the international requirements vary because of the different norms and standards, there exists a multiplicity of test procedures for the quality assurance. The whole production process is included in an extensive Total-Quality-Management-System. There are two main fields, the one is the internal quality control and the other is the external (third-party) quality control.

Generally the internal quality control is divided into three different steps:

Before production control

The raw materials and any other input are tested regarding the melting flow ratio, moisture and colour. Usually any new delivery of material is tested before it is stored. Every test is documented, analysed and filed.

During production control

During the production the individual working steps are continuously supervised and documented. Moreover the most important dimensions are measured and if necessary, corrected.

After production control

After the production, the final product is tested and compared with the requirements of the customer. The final minute is written and the documentation is finished.

In order to guarantee that the static theoretic values are conform to the reality pipes are continuously taken out of the production and they are tested with the help of a ringstiffness test according to DIN 16961 or ISO 9969.

The quality assurance demands a great know-how and therefore the Krah AG has created a Quality handbook in which all the important tests including the necessary machines are described. In order to give the customer an impression of the quality control it is possible to have a look into the handbook.

Marking

Depending on the used pipe standard, the marking can be different. A minimum marking is: The pipes shall be marked at intervals of maximum 2m, at least once per pipe.

Number of the standard, diameter serie DN/ID, manufacturer name, Stiffness Class (or Profile no.), Ring flexibility (RF30), Material code.

Quality certificates

In general the whole production is constantly supervised by a third party inspection. The quality control exceeds by far the ISO 9000 certifications because in our case the quality of the final product is tested. As result we are in the position to issue quality certificates for every delivery of pipes from the most simple quality certificate 2.2 to the first class certificate 3.1b according to EN 10204.

The advantages at a glance

Durability

Low investment costs and a service life over 100 years reduce the operating costs.

Time Saving

Up to 30% savings when laying the light and flexible pipes with lengths of 6m.

Maintenance

The smooth inner surface reduces the maintenance and cleaning costs considerably.

Hydraulics

Due to the very good hydraulic properties, smaller pipe diameters can be used compared to current traditional pipe materials.

Tightness

100% tight joints: No infiltration or exfiltration, no root penetration due to welded system.

Lengths

The standard lengths of 6m reduces the amount of joints.

Integrated E-fusion

Every pipe can have an integrated electro fusion.

Temperature resistance

Due to the machining the application of the pipes range from -40°C to +80°C.

Environmental friendly

All materials can easily be recycled and lead back into the production cycle.

Flexibility

The pipes are secure against fracture, even in case of earth movement

Easy handling

Due to the low weight and the quick assembly, the pipes are very easy to handle.



MFR-testing and moisture testing



Checking of the wall thickness



Marking of a pipe



Devices for leak tightness test of joints

krah-pipes.ee

h

KRAH

PIPES

w

s

Jõe 57B / 76605 Keila / Estonia / Tel: +372 678 1772 /
Fax: +372 678 1778 / GSM: +372 5666 5533 /
info@krah-pipes.ee / www.krah-pipes.ee